

A Performance Evaluation of Four Parallel Join Algorithms in a Shared-Nothing Multiprocessor Environment

Donovan A. Schneider
David J. DeWitt

Computer Sciences Department
University of Wisconsin
Madison, WI 53706

ABSTRACT — In this paper we analyze and compare four parallel join algorithms. Grace and Hybrid hash represent the class of hash-based join methods, Simple hash represents a looping algorithm with hashing, and our last algorithm is the more traditional sort-merge. The performance of each of the algorithms with different tuple distribution policies, the addition of bit vector filters, varying amounts of main-memory for joining, and non-uniformly distributed join attribute values is studied. The Hybrid hash-join algorithm is found to be superior except when the join attribute values of the inner relation are non-uniformly distributed and memory is limited. In this case, a more conservative algorithm such as the sort-merge algorithm should be used. The Gamma database machine serves as the host for the performance comparison.

1. Introduction

During the last 10 years, a significant amount of effort has been focused on developing efficient join algorithms. Initially, nested loops and sort-merge were the algorithms of choice. However, work by [KITS83, BRAT84, DEWI84] demonstrated the potential of hash-based join methods. Besides being faster under most conditions these hash-based join algorithms have the property of being easy to parallelize. Thus, with the trend towards multiprocessor database machines, these algorithms have received a lot of attention. In fact, several researchers, including [BRAT87, DEWI88, KITS88], have presented performance timings for a variety of parallel join algorithms. However, the more popular parallel join algorithms have never been compared in a common hardware/software environment. In this paper we present a performance evaluation of parallel versions of the sort-merge, Grace [KITS83], Simple [DEWI84], and Hybrid [DEWI84] join algorithms within the context of the Gamma database machine [DEWI86, DEWI88]. These algorithms cover the spectrum from hashing, to looping with hashing, and finally to sorting.

This research was partially supported by the Defense Advanced Research Projects Agency under contract N00039-86-C-0578, by the National Science Foundation under grants DCR-8512862, MCS82-01870, and MCS81-05904, and by a Digital Equipment Corporation External Research Grant.

Permission to copy without fee all or part of this material is granted provided that the copies are not made or distributed for direct commercial advantage, the ACM copyright notice and the title of the publication and its date appear, and notice is given that copying is by permission of the Association for Computing Machinery. To copy otherwise, or to republish, requires a fee and/or specific permission.
© 1989 ACM 0-89791-317-5/89/0005/0110 \$1.50

We feel that Gamma is a good choice for the experimental vehicle because it incorporates a shared-nothing architecture with commercially available components. This basic design is becoming increasingly popular, both in research, for example, Bubba at MCC [BORA88] and ARBRE at IBM [LORI88] and in the commercial arena, with products from Teradata [TERA83] and Tandem [TAND88].

The experiments were designed to test the performance of each of the join algorithms under several different conditions. First, we compare the algorithms when the join attributes are also the attributes used to distribute the relations during loading. In certain circumstances it is possible to exploit this situation and drastically reduce inter-processor communications. Next, the performance of each of the join algorithms is analyzed when the size of the relations being joined exceeds the amount of available memory. Our goal was to show how the performance of each algorithm is affected as the amount of available memory is reduced.¹ The join algorithms were also analyzed in the presence of non-uniform join attribute values. We also considered how effectively the different join algorithms could utilize processors without disks. Finally, bit vector filtering techniques [BABB79, VALD84] were evaluated for each of the parallel join algorithms.

The remainder of this paper is organized as follows. First, in Section 2, an overview of the Gamma database machine is presented. The four parallel join algorithms that we tested are described in Section 3. Section 4 contains the results of the experiments that we conducted. Our conclusions appear in Section 5.

2. Overview of the Gamma Database Machine

In this section we present a brief overview of the Gamma database machine. For a complete description of Gamma see [DEWI86].

2.1. Hardware Configuration

Currently², Gamma consists of 17 VAX 11/750 processors, each with two megabytes of memory. An 80 megabit/second token ring connects the processors to each other and to another

¹ This set of experiments can also be viewed as predicting the relative performance of the various algorithms when the size of memory is constant and the algorithms are required to process relations larger than the size of available memory.

² We are currently in the process of porting the Gamma software to an Intel iPSC-II Hypercube with 32 386 processors and 32 disk drives.

VAX 11/750 running Berkeley UNIX. This processor acts as the host machine for Gamma. 333 megabyte Fujitsu disk drives (8") provide database storage at eight of the processors.

2.2. Software Overview

Physical Database Design

In Gamma, all relations are horizontally partitioned [RIES78] across all disk drives in the system. Four alternative ways of distributing the tuples of a relation are provided: round-robin, hashed, range partitioned with user-specified placement by key value, and range partitioned with uniform distribution. As implied by its name, in the first strategy when tuples are loaded into a relation, they are distributed in a round-robin fashion among all disk drives. If the hashed strategy is selected, a randomizing function is applied to the "key" attribute of each tuple to select a storage unit. In the third strategy the user specifies a range of key values for each site. In the last partitioning strategy the user specifies the partitioning attribute and the system distributes the tuples uniformly across all sites.

Query Execution

Gamma uses traditional relational techniques for query parsing, optimization [SELI79], and code generation. Queries are compiled into a tree of operators with predicates compiled into machine language. After being parsed, optimized, and compiled, the query is sent by the host software to an idle scheduler process through a dispatcher process. The scheduler process, in turn, starts operator processes at each processor selected to execute the operator. The task of assigning operators to processors is performed in part by the optimizer and in part by the scheduler assigned to control the execution of the query. For example, the operators at the leaves of a query tree reference only permanent relations. Using the query and schema information, the optimizer is able to determine the best way of assigning these operators to processors.

Operating and Storage System

The operating system on which Gamma is constructed provides lightweight processes with shared memory and reliable, datagram communication services. Messages between two processes on the same processor are *short-circuited* by the communications software.

File services in Gamma are based on the Wisconsin Storage System (WiSS) [CHOU85]. These services include structured sequential files, B⁺ indices, byte-stream files as in UNIX, long data items, a sort utility, and a scan mechanism. A one page read-ahead mechanism is utilized when scanning a file sequentially.

3. Parallel Join Algorithms

We implemented parallel versions of four join algorithms: sort-merge, Grace [KITS83], Simple hash [DEWI84], and Hybrid hash-join [DEWI84]. A common feature of the parallel versions of each of these algorithms is the use of a hash function to partition each relation being joined into a collection of disjoint subsets that can be processed independently and in parallel. This partitioning is performed by applying a hash function to the join attribute of each tuple. The actual join computation depends on the

algorithm: building and probing of hash tables is used for the Simple, Grace, and Hybrid algorithms whereas sorting and merging is used for the sort-merge algorithm. As part of the partitioning process, the Grace and Hybrid algorithms first partition the two relations being joined into additional fragments when the inner relation is larger than the amount of available main memory. This is referred to as the **bucket-forming phase** [KITS83]. More details on each algorithm are presented in the following sections.

In the following discussion, R and S refer to the relations being joined. R is the smaller of the two relations and is always the inner joining relation.

3.1. Sort-Merge

Our parallel version of the sort-merge join algorithm is a straightforward adaptation of the traditional single processor version of the algorithm and is essentially identical to the algorithm employed by the Teradata machine [TERA83]. The smaller of the two joining relations, R, is first partitioned through a split table that contains an entry for each processor with an attached disk. A hash function is applied to the join attribute of each tuple to determine the appropriate disk site. As the tuples arrive at a site they are stored in a temporary file. When the entire R relation has been redistributed, each of the local files is sorted in parallel. As an example, Figure 1 depicts R being partitioned across K disk nodes into relation R'.

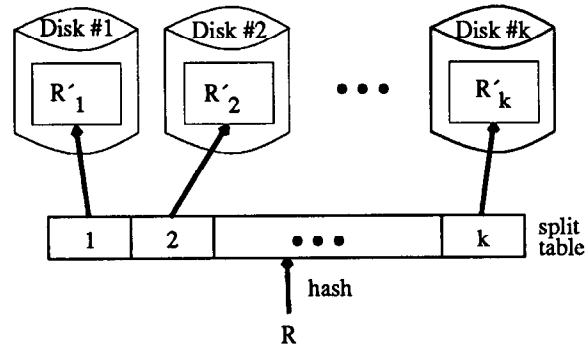

Partitioning of relation R across K disk drives for sort-merge. Figure 1

Notice that each relation fragment of R on each disk will be passed through the same split table for redistribution. Relation S is then processed in the same manner. Since the same hash function is used to redistribute both relations, only tuples within fragments at a particular site have the possibility of joining [KITS83]. Thus, a local merge join performed in parallel across the disk sites will fully compute the join.

Although it is possible to send tuples to remote, diskless processors for merging, we felt the difficulties involved (especially when the outer relation contains tuples with duplicate attribute values and hence the scan on the inner relation is required to backup) outweighed the potential benefits of offloading CPU cycles from the sites with disks. Thus, the join processors will always correspond exactly to the processors with disks.

To increase intra-query parallelism, it would be possible to partition (or sort) both relations concurrently. However, this could cause performance problems due to disk head and network interface contention. The other problem is that since bit filters

must be created from the complete inner relation before they can be applied to the outer relation, we chose to partition the relations serially.

3.2. Simple Hash

A centralized version of the Simple hash-join [DEWI84] operates as follows. First, the smaller joining relation, R , is read from disk and staged in an in-memory hash table (which is formed by hashing on the join attribute of each tuple of R). Next, the larger joining relation, S , is read from disk and its tuples probe the hash table for matches. When the number of tuples in R exceeds the size of the hash table, memory overflow occurs.

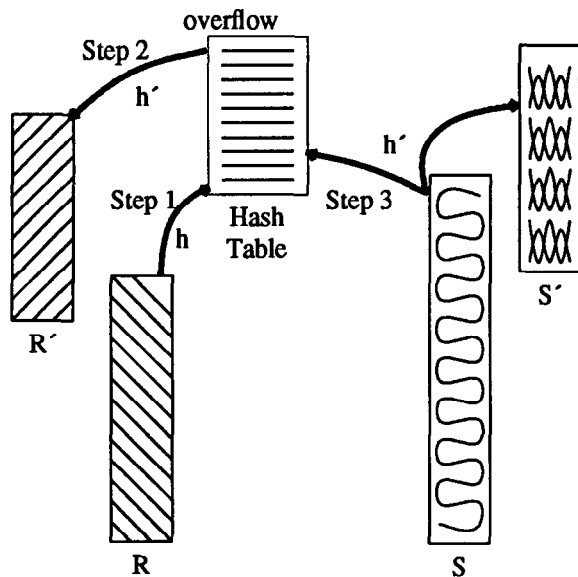

Simple hash-join overflow processing.
Figure 2

Figure 2 depicts the steps taken in order to handle this overflow. In step 1, relation R is used to build the hash table. When the hash table space is exceeded, the join operator creates a new file R' and streams tuples to this file based on a new function, h' , until the tuples in R are distributed between R' and the hash table (step 2). The query scheduler then passes the function h' to the operator producing the tuples of S , the outer relation. In step 3, tuples from S corresponding to tuples in the overflow partition (R') are spooled directly to a temporary file, S' . All other tuples probe the hash table to affect the join. We are now left with the task of joining the overflow partitions R' and S' . Since R' may also exceed the capacity of the hash table, the same process continues until no new overflow partitions are created; at which time the join will have been fully computed.

To parallelize this algorithm we inserted a split table in step 1 which routes tuples (via hashing) to their appropriate joining site. Of course, hash table overflow is now possible at any (or all) of these join sites. Overflow processing is still done, though, as described in steps 2 and 3 of the centralized algorithm. In fact, each join site that overflows has its own locally defined h' and its own associated overflow file R' . Although each overflow file is stored entirely on a single disk (i.e., not horizontally partitioned), different overflow files are assigned to different disks. Although it would have been possible to horizontally partition each overflow file across all nodes with disks, if one assumes that the

R tuples are uniformly distributed across the join nodes, all nodes should overflow to approximately the same degree. Hence, the final result will be as if the aggregate overflow partition was horizontally partitioned across the disk sites. It should be noted that the processors used for executing the join operation are not constrained to having disks as was the case for the sort-merge algorithm.

Until very recently, Simple hash was the only join algorithm employed by Gamma and is currently used as the overflow resolution method for our parallel implementations of the Grace and Hybrid algorithms.

3.3. Grace Hash-Join

A centralized Grace join algorithm [KITS83] works in three phases. In the first phase, the algorithm partitions relation R into N disk buckets by hashing on the join attribute of each tuple in R . In phase 2, relation S is partitioned into N buckets using the same hash function. In the final phase, the algorithm joins the respective matching buckets from relations R and S .

The number of buckets, N , is chosen to be very large. This reduces the chance that any bucket will exceed the memory capacity of the processor used to actually effect the join of two buckets. In the event that the buckets are much smaller than main memory, several will be combined during the third phase to form more optimal size join buckets (referred to as bucket tuning in [KITS83]).

The Grace algorithm differs fundamentally from the sort-merge and simple-hash join algorithms in that data partitioning occurs at two different stages - during bucket-forming and during bucket-joining. Parallelizing the algorithm thus must address both these data partitioning stages. To insure maximum utilization of available I/O bandwidth during the bucket-joining stage, each bucket is partitioned across all available disk drives. A **partitioning split table**, as shown in Figure 3, is used for this task. When it is time to join the i th bucket of R with the i th bucket of S , the tuples from the i th bucket in R are distributed to the available joining processors using a **joining split table** (which will contain one entry for each processor used to effect the join). As

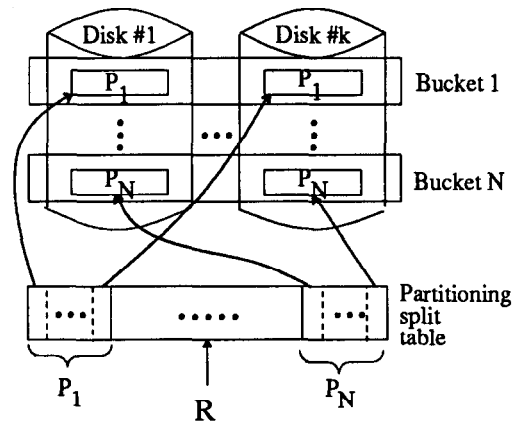

Grace Partitioning of R into N Logical Buckets
Figure 3

tuples arrive at a site they are stored in in-memory hash tables. Tuples from bucket i of relation S are then distributed using the same joining split table and as tuples arrive at a processor they probe the hash table for matches.

The bucket-forming phase is completely separate from the joining phase under the Grace join algorithm. This separation of phases forces the Grace algorithm to write both the joining relations back to disk before beginning the join stage of the algorithm.

Currently, our parallel implementation of the Grace join algorithm does not use bucket tuning. Instead, the number of buckets is determined by the query optimizer in order to ensure that the size of each bucket is just less than the aggregate amount of main-memory of the joining processors.

3.4. Hybrid Hash-Join

A centralized Hybrid hash-join algorithm [DEWI84] also operates in three phases. In the first phase, the algorithm uses a hash function to partition the inner relation, R , into N buckets. The tuples of the first bucket are used to build an in-memory hash table while the remaining $N-1$ buckets are stored in temporary files. A good hash function produces just enough buckets to ensure that each bucket of tuples will be small enough to fit entirely in main memory. During the second phase, relation S is partitioned using the hash function from step 1. Again, the last $N-1$ buckets are stored in temporary files while the tuples in the first bucket are used to immediately probe the in-memory hash table built during the first phase. During the third phase, the algorithm joins the remaining $N-1$ buckets from relation R with their respective buckets from relation S . The join is thus broken up into a series of smaller joins; each of which hopefully can be computed without experiencing join overflow. As with the Grace join algorithm, the size of the smaller relation determines the number of buckets; this calculation is independent of the size of the larger relation. Whereas the Grace join algorithm uses additional memory during the bucket-forming phase in order to produce extra buckets, Hybrid exploits this additional memory to immediately begin joining the first two buckets.

Our parallel version of the Hybrid hash join algorithm is similar to the centralized algorithm described above. A **partitioning split table** first separates the joining relations into N logical buckets. The number of buckets is chosen such that the tuples corresponding to each logical bucket will fit in the aggregate memory of the joining processors. The $N-1$ buckets intended for temporary storage on disk are each partitioned across all available disk sites as with the Grace algorithm. Likewise, a **joining split table** will be used to route tuples to their respective joining processor (these processors do not necessarily have attached disks), thus parallelizing the joining phase. Furthermore, the partitioning of the inner relation, R , into buckets is overlapped with the insertion of tuples from the first bucket of R into memory-resident hash tables at each of the join nodes. In addition, the partitioning of the outer relation, S , into buckets is overlapped with the joining of the first bucket of S with the first bucket of R . This requires that the partitioning split table for R and S be enhanced with the joining split table as tuples in the first bucket must be sent to those processors being used to effect the join. Of course, when the remaining $N-1$ buckets are joined, only the

joining split table will be needed. Figure 4 depicts relation R being partitioned into N buckets across k disk sites where the first bucket is to be joined on m diskless processors.

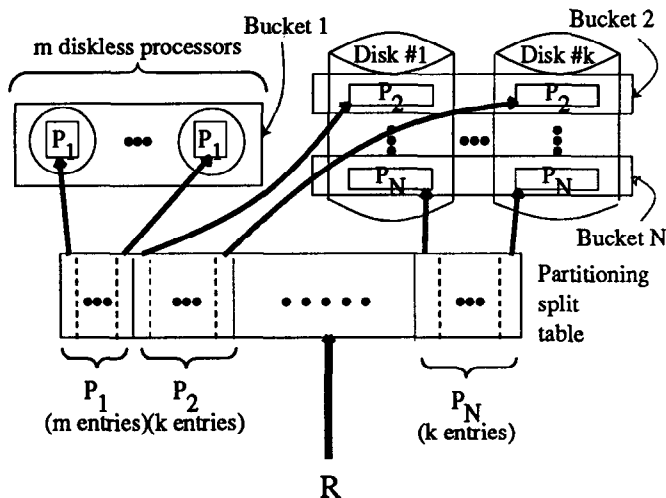

Partitioning of R into N logical buckets for Hybrid hash-join.
Figure 4

4. Experimental Results

We tested the various parallel algorithms under several conditions. First, the performance of the algorithms are studied when the attributes used to partition the joining relations at load time are also used as the joining attributes. Next, we wanted to compare the effects of bit vector filtering on the different algorithms. Third, the use of diskless processors by each of the hash-based algorithms is explored. Finally, the impact of non-uniformly distributed join attribute values on the performance of each of the algorithms is studied.

The benchmark relations are based on the standard Wisconsin Benchmark [BITT83]. Each relation consists of thirteen 4-byte integer values and three 52-byte string attributes. Except where noted otherwise, hashing on the unique1 attribute (an integer field) was used to determine each tuple's destination site during loading of the database. The benchmark join query is joinABprime, which joins a 100,000 tuple relation (approximately 20 megabytes in size) with a 10,000 tuple relation (approximately 2 megabytes in size) and produces a 10,000 tuple result relation (over 4 megabytes in size). We ran the experiments with the other benchmark join queries, joinAse1B and joinCse1Ase1B, but the trends were the same so those results are not presented. 8 kilobyte disk pages were used in all experiments. The default hardware environment consists of eight processors with disks and a single diskless processor reserved for query scheduling and global deadlock detection. We refer to this configuration as **local** because joins will be performed on the sites with attached disks. In Section 4.3, we explore the performance of the Simple, Grace, and Hybrid algorithms when 8 diskless processors are added. This configuration is termed **remote**.

Join performance (for each of these parallel join algorithms) is very sensitive to the amount of available memory relative to the size of the joining relations. In designing the set of experiments described below, one of the first decisions we had to make

was how to capture this aspect of the performance of the different algorithms. One approach would have been to keep the amount of available memory constant while varying the size of the two relations being joined. The other choice was to keep the size of the joining relations constant while (artificially) varying the amount of memory available. We rejected the first choice because increasing the size of the joining relations has the side-effect of increasing the number of I/O's needed to execute the query.

Our experiments analyze join performance over a wide range of memory availability. All results are graphed with the x-axis representing the ratio of available memory to the size of the smaller relation. Note that available memory is the sum of the memory on the joining processors that is available for use to effect the join. In the case of the hash-based join algorithms, this memory is used to construct an in-memory hash table. For the sort-merge join algorithm, this memory is used for both sorting and merging. In the case of the sort-merge join algorithm, we simply reduced the amount of sort/merge space and for the Simple-hash join algorithm we reduced the amount of hash table space, accordingly. For the Grace and Hybrid algorithms, however, a data point at 0.5 relative memory availability, for instance, equates to a two-bucket join. Likewise, a data point at 0.20 was computed using 5 buckets. Thus, neither Grace or Hybrid joins experienced hash table overflow.

4.1. HPJA vs. Non-HPJA Joins: Local configuration

In Gamma and Teradata, when a relation is created, the database administrator is required to specify a partitioning or "key" attribute and, in the case of Gamma, a partitioning strategy: round-robin, hashed, or range (see Section 2 for more details). If the two relations being joined are both hash-partitioned on their joining attributes (termed a HPJA join), the partitioning phase of each of the parallel algorithms described in the previous section is no longer necessary and can be eliminated. Rather than special-case the system to handle a join operation on the partitioning attribute, Gamma relies on its operating system to "short-circuit" packets between two processes on the same machine and the design of the partitioning split table to maximize the extent to which tuples are mapped to hash-join buckets at the same processor.

Figures 5 and 6 display the execution times of the joinABprime query as a function of the amount of memory available relative to the size of the inner relation when the join attributes are the partitioning attributes (Figure 5) and when they are not (termed a non-HPJA join, see Figure 6). These tests were conducted using the "local" configuration of processors in which the joins are executed only on the 8 processors with disks. Several points should be made about these graphs. First, when the smaller relation fits entirely in memory (at 1.0), Hybrid and Simple algorithms have, as expected, identical execution times.

As expected, Grace joins are relatively insensitive to decreasing the amount of available memory but Hybrid is very sensitive, especially when the percentage of available memory relative to the size of the joining relations is large. This occurs because the Grace algorithm is not using the extra memory for joining and hence decreasing memory simply increases the number of buckets, each of which incurs a small scheduling overhead. However,

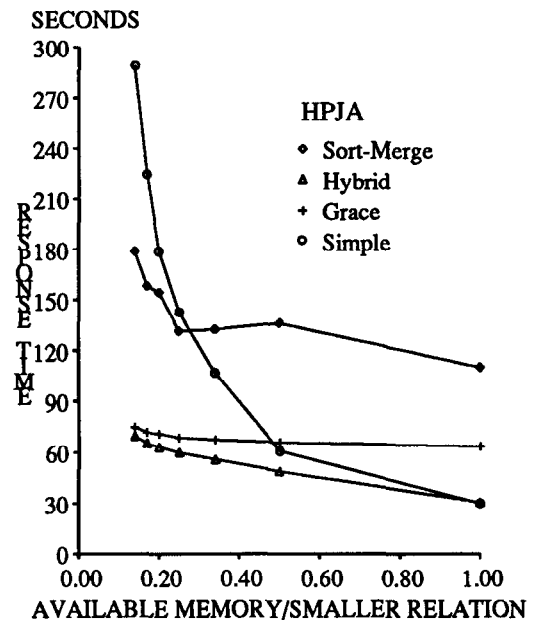

Figure 5
Partitioning Attributes Used as Join Attributes
8 Processors with Disks

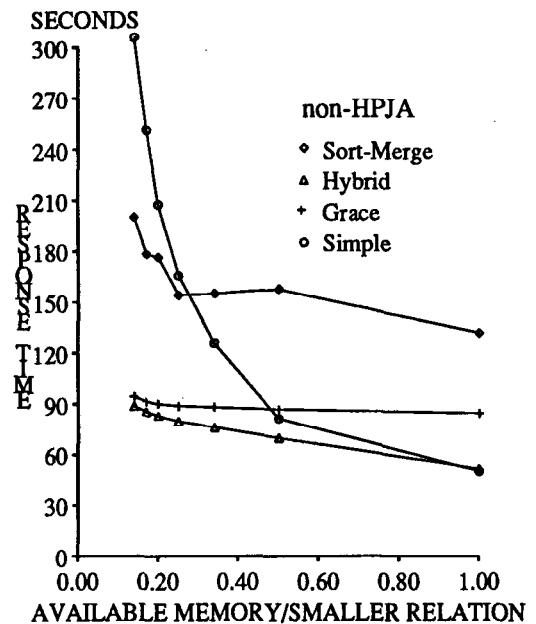

Figure 6
Partitioning Attributes Not Used as Join Attributes
8 Processors with Disks

for Hybrid, decreasing the amount of memory available from a ratio of 1.0 to 0.5 forces the algorithm to stage half of each joining relation back to disk. Furthermore, note that the response time for the Hybrid algorithm approaches that of the Grace algorithm as memory is reduced. Hybrid derives its benefits from exploiting extra memory and, when this memory is reduced, the relative performance of the algorithm degrades.

For both Figures 5 and 6, the Hybrid algorithm dominates over the entire available memory range. Between the memory ratios of 0.5 and 1.0, Simple hash outperforms Grace and sort-

merge because a decreasing fraction of the larger joining relation is written back to disk. However, as memory availability decreases, Simple hash degrades rapidly because it repeatedly reads and writes the same data. While the performance of the Sort-merge algorithm is relatively stable, it is dominated by Hybrid and Grace algorithms over the entire memory range. The upward steps in the response time curves for sort-merge result from the cost of the additional merging passes that are required to sort the larger source relation. An interesting feature of the sort-merge curves is the drop in response time as the memory ratio is decreased from 0.5 to 0.25. Although we are entirely not sure why this phenomenon occurs (about a 3% difference), we hypothesize that, while the number of merge passes required for sorting the larger joining relation is constant over this memory range, adding additional sort buffers really just adds processing overhead.

It is important to point out that the trends observed in these graphs and their general shape are almost identical to the analytical results reported in [DEWI84] and the experimental results in [DEWI85] for single-processor versions of the same algorithms. There are several reasons why we find this similarity encouraging. First, it demonstrates that each of the algorithms parallelizes well. Second, it serves to verify that our parallel implementation of each algorithm was done in a fair and consistent fashion.

It is interesting to note that the corresponding curves in Figures 5 and 6 differ by a constant factor over all memory availabilities tested. With sort-merge, since the join attributes of the two relations have the same range of values, regardless of whether they are partitioning attributes or not, the time to sort and merge will be constant. However, when relations R and S are partitioned across the joining sites, HPJA joins will shortcircuit all tuples in both R and S. Non-HPJA joins, however, will only shortcircuit 1/8th of the tuples. This shortcircuiting difference accounts for the response time difference.

Simple hash will experience the same effects as the set of joining processors is the same as with sort-merge. However, one might have expected that HPJA joins would increasingly reap the benefits of shortcircuiting when processing join overflows. These savings never materialize because the hash function is changed after each overflow, thus converting HPJA joins into non-HPJA joins. This hash function modification is necessary in order to efficiently process non-uniform data distributions. Consider the case where only a subset of the joining sites overflow. If the same joining hash function is used when the tuples from the overflow partition are read from disk and re-split, all the overflow tuples will re-map to the same overflowing processors. Unfortunately, this will leave the non-overflowing processors idle and perhaps more importantly, their associated local memories unused.

The explanation for Grace joins is slightly more complicated. Independent of the amount of memory available, partitioning of R and S into buckets will be completely shortcircuited for HPJA joins while only 1/8th of the tuples will be shortcircuited for non-HPJA joins. Since this accounts for the total response time difference between HPJA and non-HPJA joins, this implies that the joining phases for the HPJA and non-HPJA attribute joins must be identical, and furthermore that all joining tuples will shortcircuit the network. Why is this the case? We can argue intuitively that this should be the case in a good implementation.

The important feature of using hashing in a parallel join algorithm is that the join is broken into buckets, each of which can be processed independently of one another. Obviously, this is what Grace joins do; tuples in bucket j of R are only compared with tuples in bucket j of S. But this technique can be applied to a finer level than buckets. In Figure 3, one saw that each logical bucket is composed of a number of physical fragments. Since these fragments are created by hashing (via the partitioning split table), we are only required to join tuples in fragment i of bucket j of R with tuples from fragment i of bucket j of S, where i ranges from 1 to the number of disk sites and j ranges from 1 to N. Since the corresponding fragments of buckets j of R and S reside on the same disk (since the same partitioning split table is used for R and S), there is no need to redistribute these tuples during a join when only processors with disks are used to perform the join operation. Thus, with the Grace join algorithm, non-HPJA joins become HPJA joins after the initial bucket-forming partitioning phase has been completed.

The performance difference between HPJA and non-HPJA Hybrid joins is easy to explain given their similarity to Grace joins. With the "Local" configuration, a N-bucket Hybrid join will have a partitioning split table identical to that of a N-bucket Grace join with the exception that tuples in the first bucket will be joined immediately instead of being stored in temporary files. Since the joining split table is identical for both algorithms, all tuples will shortcircuit the network during the processing of all N buckets (as was the case with Grace joins). Thus, the difference in execution time between HPJA and non-HPJA Hybrid joins is due to the cost of partitioning R and S into buckets when the join attributes are the HPJA and when they are not.

4.2. Multiprocessor Bit Vector Filtering

In the next set of experiments we ran the joinABprime tests using bit filters [BABB79, VALD84]. With the sort-merge algorithm, a bit filter is built at each disk site as the inner (smaller) relation is partitioned across the network and stored in temporary files. With the hash-based algorithms, a bit filter is built at each of the join sites as tuples from the inner relation are being inserted into the hash tables. This filter is then used to eliminate non-joining tuples from the outer relation.

In our implementation, bit filtering of tuples is only applied during the joining phase. With the Simple hash-join algorithm this means that as the number of overflows increases, the opportunities for filtering out non-joining tuples increases (because each overflow is treated as a separate join). With Grace and Hybrid joins, each bucket is treated as a separate join. Thus, separate bit filters will be built as a part of processing each bucket. Since each join uses the same size bit filter, increasing the number of buckets (or overflows) increases the effective size of the aggregate bit filter across the entire join operation.

Figure 7 shows the results for HPJA joins with bit filtering applied. (Non-HPJA join results are not shown because, as was the case with non-HPJA joins in Figure 6, the trends are the same.) Again, these tests were conducted using only the 8 CPUs with disks. Notice that the relative positions of the algorithms have not changed, only the execution times have dropped in comparison to the results shown in Figure 5. The performance improvements from bit filtering for each individual algorithm are

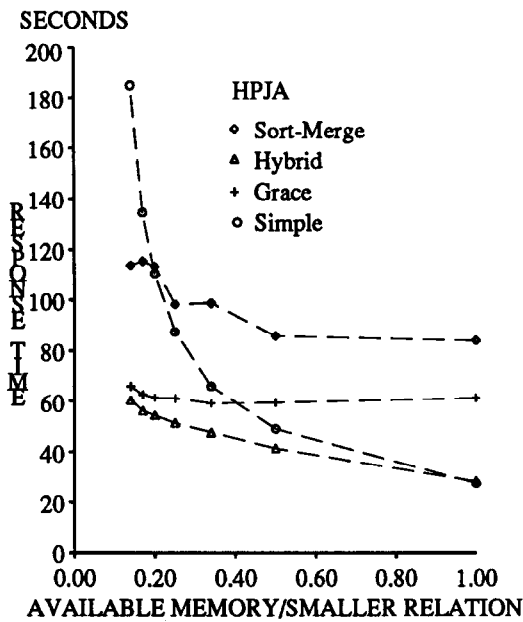

Figure 7
Bit Vector Filtering
8 Processors with Disks

shown in Figures 8 through 11. An interesting effect to note is the shape of the curves for the Grace join algorithm as memory is reduced. Execution time actually falls until the available memory ratio reaches 25% (4 buckets) and then begins to rise. This is explained by our implementation of bit filtering. With 100% available memory, all 10,000 tuples (approximately 1,250 at each site) will attempt to set a bit in the filter. Since, Gamma currently uses only a single 2Kbyte packet for a filter (which is shared across all 8 joining sites - yielding 1,973 bits/site after overhead),

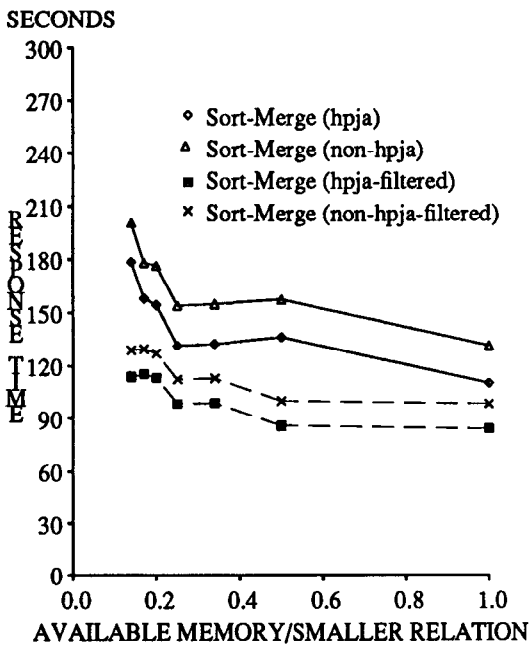

Figure 8

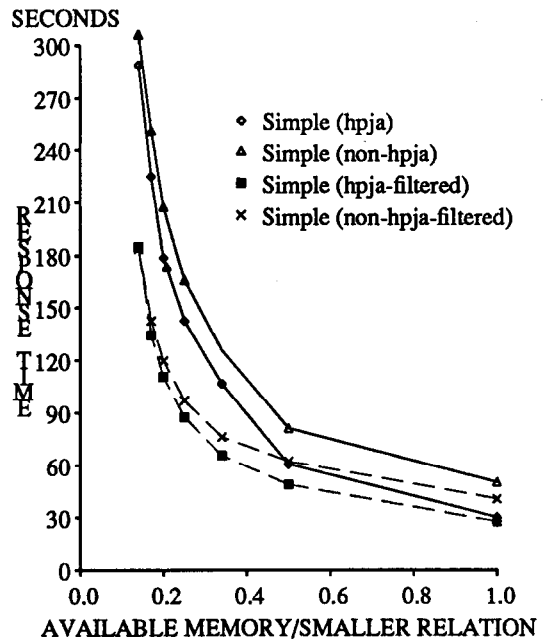

Figure 9

most bits are set and hence the effectiveness of the filter is low. Thus, only a small percentage of the probing tuples are eliminated by the filter. However, as memory is decreased and the number of buckets increases a separate 2K filter is used for the join of each bucket. With two buckets, the gains from eliminating additional probing tuples exceeds the cost of scheduling the extra bucket and response time drops. This effect keeps occurring until four buckets are used and all non-joining tuples have been eliminated by filtering.

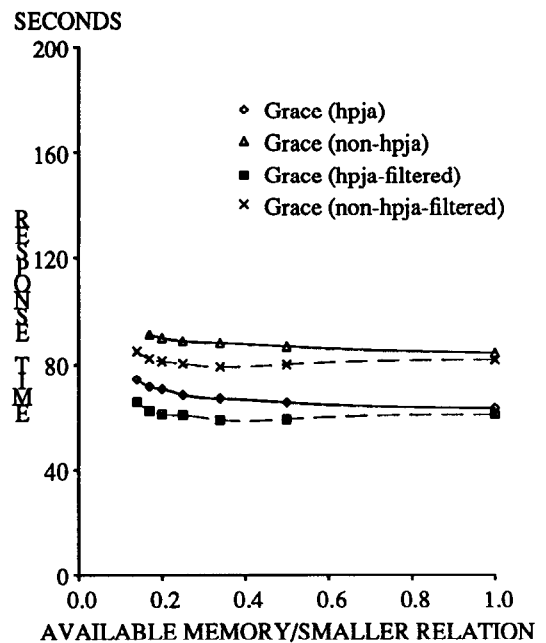

Figure 10

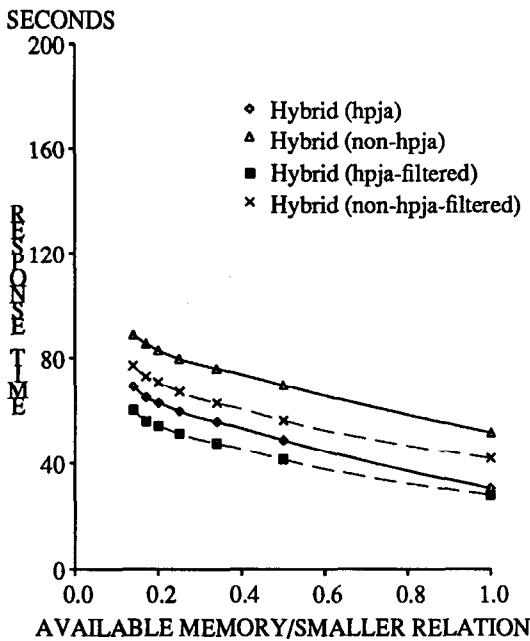

Figure 11

The Hybrid join algorithm experiences the same bit filtering effects but the result is not as obvious because as the amount of available memory is reduced the amount of disk I/O increases. Thus it is harder to isolate the effects of bit filtering than with the Grace algorithm.

A similar effect occurs for Simple hash-join. As memory is reduced (and overflows occur more frequently) more tuples are eliminated by the bit filters. As you can see, large bit filters are necessary for low response times for Simple hash-join. Eliminating non-joining tuples early will avoid writing these tuples to disk and later reading them multiple times.

The performance of the sort-merge join algorithm also benefits significantly from the use of bit filters, even though only a single 2K filter is used. Tuples of the outer relation that are eliminated by the filter do not need to be written to disk, sorted, and later read during merging. Obviously using a larger bit filter would further improve the performance of each of these join algorithms. It should also be noted that extending filtering techniques to the bucket-forming phases of the Grace and Hybrid join algorithms would also improve performance.

4.3. Remote Joins: HPJA vs. Non-HPJA

Since Gamma can use diskless processors for performing join and aggregate operations, the goal of the tests described in this section was to explore the effect of using diskless processors on the performance of the different join algorithms. The sort-merge algorithm has been excluded from this section because our current implementation of this algorithm cannot utilize diskless processors.

Although Gamma is capable of executing a join operation on a mix of processors with and without disks, earlier tests for the Simple hash-join algorithm [DEWI88] indicated the performance of such a configuration was almost always 1/2 way between that of the "local" and "remote" configurations. Thus, for the

following experiments, 8 processors with disks were used for storing the relations and 8 diskless processors performed the actual join computation. The Hybrid, Simple, and Grace algorithms were tested using this "remote" configuration and the results for the joinABprime query are displayed in Figure 12.

For the Grace algorithm, the difference in execution time between HPJA and non-HPJA joins is constant over the entire range of memory availability. This occurs because the execution time of the bucket-forming phase is constant regardless of the number of buckets, i.e., both source relations are completely written back to disk. The response time difference between the HPJA and non-HPJA joins reflects the savings gained by shortcircuiting the network during the bucket-forming phases for the HPJA joins. Shortcircuiting also explains the spreading difference shown for Hybrid joins. With 100% available memory, all tuples will be shipped remotely during the processing of the join, for both types of joins. However, when only half the required memory is available, HPJA joins will write half the building and probing tuples to disk locally during the bucket-forming phase of the algorithm, thus shortcircuiting the network. Non-HPJA joins will write only 1/16th of these same tuples locally. Table 1 presents the difference in the percentage of local writes for HPJA and non-HPJA joins.

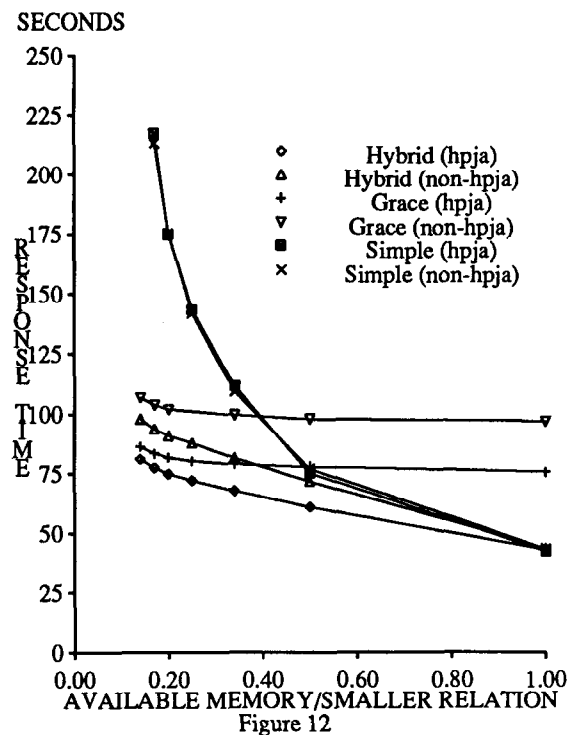

Joins Executed on 8 Diskless Processors

| Join Type | Number of Buckets | | | | | |
|------------|-------------------|------|------|------|------|------|
| | 1 | 2 | 3 | 4 | 5 | 6 |
| HPJA | 0 | 1/2 | 2/3 | 3/4 | 4/5 | 5/6 |
| Non-HPJA | 0 | 1/16 | 2/24 | 3/32 | 4/40 | 5/56 |
| Difference | 0 | .438 | .583 | .656 | .717 | .744 |

Fraction of local writes during redistribution for HPJA and non-HPJA Hybrid joins.

Table 1

Analyzing this table shows that as the number of buckets increases (ie. memory is reduced), the relative savings of local writes for HPJA joins increases over that for non-HPJA joins.

The fact that non-HPJA joins perform the same as HPJA joins for Simple hash-join may seem puzzling at first. As memory is reduced the curves do not spread as with Hybrid because the hash function is changed after the first overflow, hence turning all joins into non-HPJA joins³.

Local vs. Remote Joins: HPJA

A comparison of the performance of "local" and "remote" joins for HPJA joins is shown in Figure 13. With Grace joins, the cost of bucket-forming is constant regardless of where the join processing is performed and, since these are HPJA joins, bucket-forming will shortcircuit all tuples. However, during the joining phase, tuples will be distributed to the join processors for building and probing. When joins are done locally, all these tuples will shortcircuit the network (in addition to 1/8th of the result tuples). With remote-join processing, none of these shortcircuiting benefits will be realized during the joining phase. The same explanation describes the observed Hybrid join performance. Please refer to [DEWI88] for an explanation for the observed crossover in the graphs for the Simple hash-join algorithm.

Local vs. Remote Joins: Non-HPJA

With non-HPJA joins, the results presented in the previous sub-section no longer hold. Figure 14 shows the performance of the three hash-join algorithms on non-partitioning attributes for both the "local" and "remote" configurations. We consider Grace joins first. As Figure 14 demonstrates, local joins have superior performance to remote joins by a constant margin over the entire range of available memory. Since the bucket-forming phase of the Grace algorithm involves only the processors with disks, the execution time of this phase is constant regardless of what processors are used for the actual join operation. At a memory ratio of 1.0, one would then expect the join phase of the Grace algorithm to behave exactly like that of a one-bucket Hybrid join. But, as you can see, Hybrid executes joins on diskless processors faster at this memory ratio. What is the cause of this inconsistency? Recall from Section 4.1 that with the Grace algorithm non-HPJA joins effectively become HPJA joins after the bucket-forming phase. Thus, the results obtained for HPJA joins that

³See Section 4.1 for the motivation behind this change in hash functions.

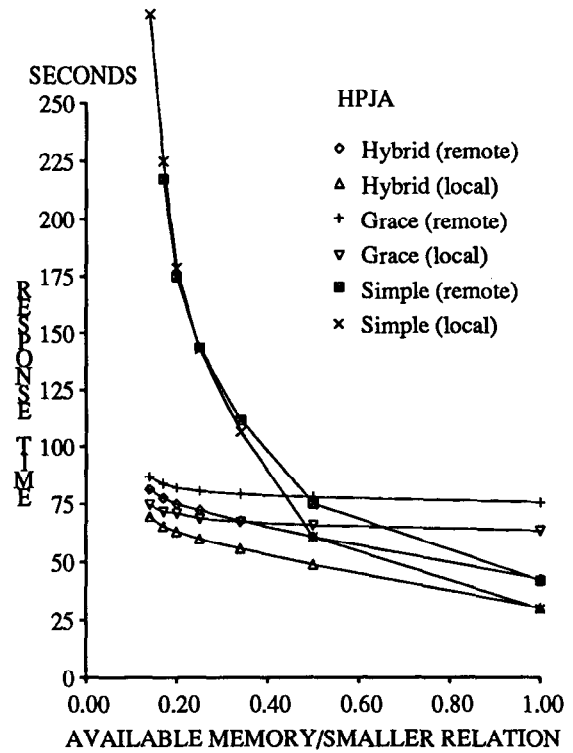

Figure 13
Partitioning Attributes Used as Join Attributes

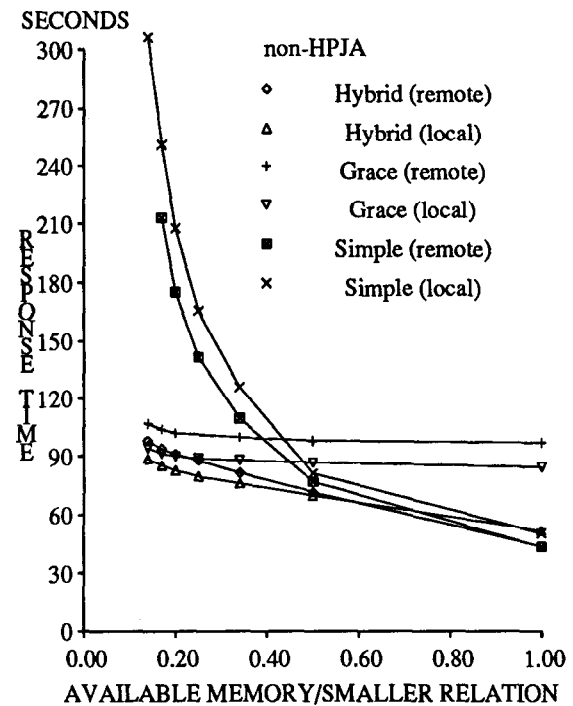

Figure 14
Partitioning Attributes Not Used as Join Attributes

were described in the previous section and displayed in Figure 13 can be directly applied in this case. As one can see, the same difference between local and remote response time exists, although the non-HPJA join times are slower than the HPJA join

times because of the increased costs of bucket-forming.

The discussion contained in Section 4.1 also explains the performance of the Hybrid algorithm. At 100% memory availability, bucket-forming and joining are completely overlapped. Since these experiments involve non-HPJA joins, tuples will be distributed across all the joining processors resulting in substantial network traffic. Remote processing wins in this case because, since the joining relations tuples need to be distributed across the processors anyway, the CPU cycles necessary for building and probing the hash tables can be successfully offloaded to the diskless processors. But, as memory is reduced "Local" joins become better and better. The partitioning phenomena discussed for Hybrid joins in Section 4.1 explains this shift in performance. At a memory availability of 50%, half of the tuples being joined will be written to disk. When this disk bucket is subsequently joined it will effectively become a HPJA join. As memory is further reduced a larger fraction of the join becomes like a HPJA join and, as illustrated by Figure 13, HPJA joins can be executed faster locally than remotely. This explains why the curves crossover and the difference widens as memory is reduced.

Performance of the Simple hash-join algorithm is easy to explain. It is fastest with remote processors at 100% memory availability for the same reasons given for Hybrid. However, it doesn't crossover like Hybrid because its writing and subsequent reading of overflow files never benefits from shortcircuiting as the modification of the hash function after each hash table overflow eliminates the possibility of ever achieving the performance observed with HPJA joins.

4.4. Non-Uniform Data Distributions

In this set of experiments we wanted to analyze the performance of the four parallel join algorithms in the presence of non-uniformly distributed join attribute values. In order to isolate the effects of the non-uniform data distributions we varied the distribution of the two join attribute values independently. Figure 15 shows these four possible combinations that comprised our experimental design space. The key we are using in this figure is XY, where X (Y) represents the attribute value distribution of the inner (outer) relation. U = Uniform distribution and N = Non-uniform distribution.

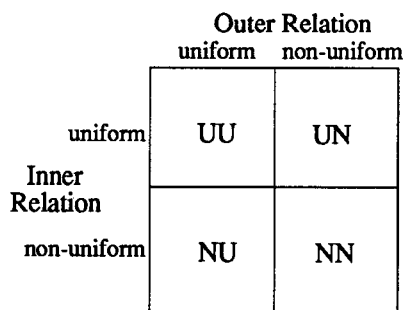

Figure 15

The response time of the joinABprime query is again used as the performance metric for this set of experiments. Recall that this query joins a 100,000 tuple relation (20 megabytes) with a 10,000 tuple relation (2 megabytes). The 10,000 tuple relation is the inner (building) relation and the 100,000 tuple relation is the outer (probing) relation. For the non-uniform distribution we

chose the **normal** distribution with a mean of 50,000 and a standard deviation of 750. These parameters resulted in a highly skewed distribution of values over the domain 0-99,999. In fact, 12,500 tuples had join attribute values in the range 50,000 to 50,243. However, no single attribute value occurred in more than 77 tuples. The 10,000 tuple relation was created by randomly selecting 10,000 tuples from the 100,000 tuple relation. Thus the 10,000 tuple relation's primary key had values uniformly distributed from 0 to 99,999. Also, the normally distributed attribute had the same characteristics for its distribution for the 10,000 tuple relation as it did for the 100,000 tuple relation.

To ensure that each processor did the same amount of work during the initial scan of the two relations being joined, we distributed each of the relations on their join attribute by using the range partitioning strategy provided by Gamma. This resulted in an equal number of tuples on each of the eight disks.

As in the previous experiments we used the amount of memory relative to the size of the smaller joining relation as a basis for comparing the join algorithms. Remember, though, that the amount of memory at each joining processor is sufficient to hold its share of tuples from the inner relation **only** if the tuples are distributed evenly across the processors. Eight processors with disks were used for these experiments.

Table 2 presents the results for each of the parallel join algorithms for the cases of 100% and 17% memory availability. The UU joins produced a result relation of 10,000 tuples as did the NU joins. The UN joins produced 10,036 result tuples. Results for the NN joins are not presented as the result cardinality for this query was 368,474 tuples. We could find no way of normalizing these NN results to meaningfully compare them with the results from the other three join types. We analyze the performance of each of the join algorithms with the addition of bit vector filters in the next subsection.

| Algorithm | 100% memory | | | 17% memory | | |
|---------------------|-------------|--------|--------|------------|--------|--------|
| | UU | NU | UN | UU | NU | UN |
| Hybrid w/filter | 51.48 | 57.27 | 51.37 | 85.74 | 111.36 | 88.87 |
| | 36.84 | 30.04 | 37.74 | 73.60 | 89.39 | 78.20 |
| Grace w/filter | 84.13 | 84.53 | 84.83 | 92.90 | 97.89 | 95.66 |
| | 79.37 | 76.07 | 79.93 | 83.20 | 87.89 | 87.28 |
| Sort-Merge w/filter | 167.44 | 149.45 | 163.81 | 210.91 | 195.78 | 209.37 |
| | 101.27 | 66.24 | 99.03 | 125.06 | 70.91 | 124.88 |
| Simple w/filter | 51.13 | 57.76 | 51.63 | 251.37 | 259.30 | 246.84 |
| | 36.57 | 30.53 | 38.00 | 167.08 | 121.65 | 164.41 |

Join results with non-uniform join attribute value distributions. (All response times are in seconds)

Table 2

We begin by analyzing the effects of using non-uniformly distributed join attribute values for the inner (building) relation by comparing the NU results with the UU results. For the hash-join algorithms two major factors result from "building" with a non-uniformly distributed attribute. First, tuples will not generally be distributed equally among the physical bucket fragments. Second, chains of tuples will form in the hash tables due to

duplicate attribute values. The first factor is significant because some processors will have more work than others and because the aggregate memory allocated for the join was sufficient to hold the building relation's tuples only if the tuples were uniformly spread across the joining processors. With the normally distributed join attribute values used in our experiments, the hash function could not distribute the relation uniformly and memory overflow resulted. However, the hash function did not perform that poorly and only one pass of the overflow mechanism was necessary to resolve the overflow of each join bucket. The second factor, chains of tuples forming in the hash tables, also occurred with normally distributed join attribute values. In fact, chains of 3.3 tuples were found on the average, with a maximum hash chain length of 16.

Table 2 shows that NU is indeed slower than UU for these hash-based join algorithms. Since the philosophy behind the Grace join algorithm is to use many small buckets to prevent buckets from overflowing, we executed this algorithm using one additional bucket so that memory overflow would not occur. At 100% memory availability, the Hybrid algorithm processes the overflow fairly efficiently. However, as memory is reduced, each bucket-join in the Hybrid algorithm experiences overflow. As shown by the results at 17% memory availability, the cost of overflow resolution becomes significant.

Why, though, does the sort-merge join algorithm run NU faster than UU and UN? The hashing function will distribute tuples unevenly across the joining processors exactly as it did for the other algorithms, thereby requiring a subset of the sites to store to disk, sort, and subsequently merge more tuples than others. This will surely have a negative impact on response time. The explanation has to do with recognizing how the merge phase of the join works. Since the join attribute of the inner relation is highly skewed (the maximum join attribute value is only 53,071) the merge phase does not need to read all of the outer (100K) relation. In this case, the semantic knowledge inherent in the sort-order of the attributes allowed the merge process to determine the join was fully computed before all the joining tuples were read. A similar effect occurs for UN but it is not as significant because only part of the inner (10K) relation can be skipped from reading; all the 100K outer relation must still be read.

The effects of a non-uniform distribution of join attribute values in the outer relation can be determined by comparing the UN results with the UU results. The first effect is that an unequal numbers of tuples are distributed to the joining processors. At 100% memory availability no noticeable effects are shown (except for sort-merge as discussed above). However, as memory is reduced small differences appear for both the Hybrid and Grace algorithms. This occurs because as memory is reduced the joining relations are first divided up into buckets. Because the outer join attribute is non-uniformly distributed, the outer relation will not be uniformly divided among the buckets. The result is that some of the disk sites require additional disk I/Os during the bucket forming and bucket joining phases. Thus, as the number of buckets increases the effects of having non-uniformly distributed join attribute values become more significant.

We feel these UN results are very encouraging for the Hybrid join algorithm. One can argue that many joins are done to re-establish relationships. These relationships are generally one-to-

many and hence one join attribute will be a key. Since the relation on the "one" side is probably smaller it will be the building relation in a hash-join algorithm. Thus, this case will result in a UN type of join which we have shown can be efficiently processed.

Bit Vector Filtering

As expected, Table 2 shows that the application of bit vector filters improves the performance of each of the parallel join algorithms. Table 3 presents the percentage improvement provided by using bit filters for each of the join algorithms.

| Algorithm | 100% memory | | | 17% memory | | |
|------------|-------------|-------|-------|------------|-------|-------|
| | UU | NU | UN | UU | NU | UN |
| Hybrid | 28.4% | 47.6% | 26.5% | 14.2% | 19.7% | 12.0% |
| Grace | 5.7% | 10.0% | 5.8% | 10.4% | 10.2% | 8.8% |
| Sort-Merge | 39.5% | 55.7% | 39.5% | 40.7% | 63.8% | 40.4% |
| Simple | 28.5% | 47.1% | 26.4% | 33.5% | 53.1% | 33.4% |

Percentage improvement using bit vector filters.

Table 3

As shown, the sort-merge and Simple join algorithms experience the greatest improvement from bit filtering. This occurs because filtering tuples eliminates a large number of disk I/Os. The performance of the Grace join algorithm is improved the least because filtering is only applied during bucket-joining and not during bucket-forming. Thus, no disk I/O is eliminated by using bit filters with this algorithm. As stated in Section 4.2, extending bit filtering to the bucket-forming phases of the Grace and Hybrid algorithms would significantly increase the performance of these algorithms.

Within each join algorithm the NU join type experienced the greatest improvements from filtering because the normally distributed attribute values resulted in more collisions when setting bits in the bit filter. Thus, fewer bits were set in the filter. This has the effect of screening out more outer (probing) tuples. Sort-merge has the best filtering improvement for NU because the better filtering enabled the outer relation to be sorted in one less pass.

5. Conclusions and Future Work

Several conclusions can be drawn from these experiments. First, for uniformly distributed join attribute values the parallel Hybrid algorithm appears to be the algorithm of choice because it dominates each of the other algorithms at all degrees of memory availability. Second, bit filtering should be used because it is cheap and can significantly reduce response times.

However, non-uniformly distributed join attribute values alter the relative performance of the parallel join algorithms. The performance of the hash-based join algorithms, Hybrid, Grace and Simple, degrades when the join attribute values of the inner relation are non-uniformly distributed. In the case where the join attribute values are highly skewed and the available memory relative to the size of the smaller relation is limited, the optimizer

should choose a non-hash-based algorithm such as sort-merge. We find it very encouraging, though, that the Hybrid join algorithm still performs best when the joining attribute of the outer relation is non-uniformly distributed. We expect this type of join to be very common in the case of re-establishing one-to-many relationships.

From the results presented, one might be tempted to conclude that using remote processors for executing join operators is not a good idea except when the Hybrid algorithm is used with sufficient available memory and the join is a non-HPJA join. This may not be as restrictive as it seems as a relation can only have one partitioning attribute. Hence, non-HPJA joins may be fairly likely. In addition, when Gamma processes joins "locally", the processors are at 100% CPU utilization. However, when the "remote" configuration is used, CPU utilization at the processors with disk drops to approximately 60%. Thus, in a multiuser environment, offloading joins to remote processors may permit higher throughput by reducing the load at the processors with disks. We intend on studying the multiuser tradeoffs in the near future.

Several opportunities exist for expanding on the work done. For instance, currently only a single join process operates on a processor at a time. We would like to look at increasing the amount of intra-query parallelism. Dynamically adjusting the number of join processes depending on load information would also be very interesting.

6. References

- [BABB79] Babb, E., "Implementing a Relational Database by Means of Specialized Hardware" ACM Transactions on Database Systems, Vol. 4, No. 1, March, 1979.
- [BITT83] Bitton, D., D.J. DeWitt, and C. Turbyfill, "Benchmarking Database Systems - A Systematic Approach," Proceedings of the 1983 Very Large Database Conference, October, 1983.
- [BORA88] Boral, H. "Parallelism in Bubba," Proceedings of the International Symposium on Databases in Parallel and Distributed Systems, Austin, TX, December, 1988.
- [BRAT84] Bratbergsengen, Kjell, "Hashing Methods and Relational Algebra Operations" Proceedings of the 1984 Very Large Database Conference, August, 1984.
- [BRAT87] Bratbergsengen, Kjell, "Algebra Operations on a Parallel Computer -- Performance Evaluation", *Database Machines and Knowledge Base Machines*, M. Kitsuregawa and H. Tanaka (eds), Kluwer Academic Publishers, 1987.
- [CHOU85] Chou, H-T, DeWitt, D. J., Katz, R., and T. Klug, "Design and Implementation of the Wisconsin Storage System (WiSS)" Software Practices and Experience, Vol. 15, No. 10, October, 1985.
- [DEWI84] DeWitt, D. J., et. al., "Implementation Techniques for Main Memory Database Systems," Proceedings of the 1984 SIGMOD Conference, Boston, MA, June, 1984.
- [DEWI85] DeWitt, D., and R. Gerber, "Multiprocessor Hash-Based Join Algorithms," Proceedings of the 1985 VLDB Conference, Stockholm, Sweden, August, 1985.
- [DEWI86] DeWitt, D., Gerber, B., Graefe, G., Heytens, M., Kumar, K. and M. Muralikrishna, "GAMMA - A High Performance Dataflow Database Machine," Proceedings of the 1986 VLDB Conference, Japan, August 1986.
- [DEWI88] DeWitt, D., Ghandeharizadeh, S., and D. Schneider, "A Performance Analysis of the Gamma Database Machine", Proceedings of the 1988 SIGMOD Conference, Chicago, IL, June 1988.
- [KITS83] Kitsuregawa, M., Tanaka, H., and T. Moto-oka, "Application of Hash to Data Base Machine and Its Architecture," *New Generation Computing*, Vol. 1, No. 1, 1983.
- [KITS88] Kitsuregawa, M., Nakano, M., and M. Takagi, "Query Execution for Large Relations On Functional Disk System," to appear, 1989 Data Engineering Conference.
- [LORI88] Lorie, R., et. al., "Adding Intra-Transaction Parallelism to an Existing DBMS: Early Experience", RJ 6165, IBM Almaden Research Center, March 1988.
- [RIES78] Ries, D. and R. Epstein, "Evaluation of Distribution Criteria for Distributed Database Systems," UCB/ERL Technical Report M78/22, UC Berkeley, May, 1978.
- [SELI79] Selinger, P. G., et. al., "Access Path Selection in a Relational Database Management System," Proceedings of the 1979 SIGMOD Conference, Boston, MA., May 1979.
- [TAND88] Tandem Performance Group, *A Benchmark of Non-Stop SQL on the Debit Credit Transaction*, Proceedings of the 1988 SIGMOD Conference, Chicago, IL, June 1988.
- [TERA83] Teradata Corp., *DBC/1012 Data Base Computer Concepts & Facilities*, Teradata Corp. Document No. C02-0001-00, 1983.
- [VALD84] Valduriez, P., and G. Gardarin, "Join and Semi-Join Algorithms for a Multiprocessor Database Machine" ACM Transactions on Database Systems, Vol. 9, No. 1, March, 1984.